

Standard cylinder—SAI Series

In accordance with ISO15552 standard

Compendium of SAI Series

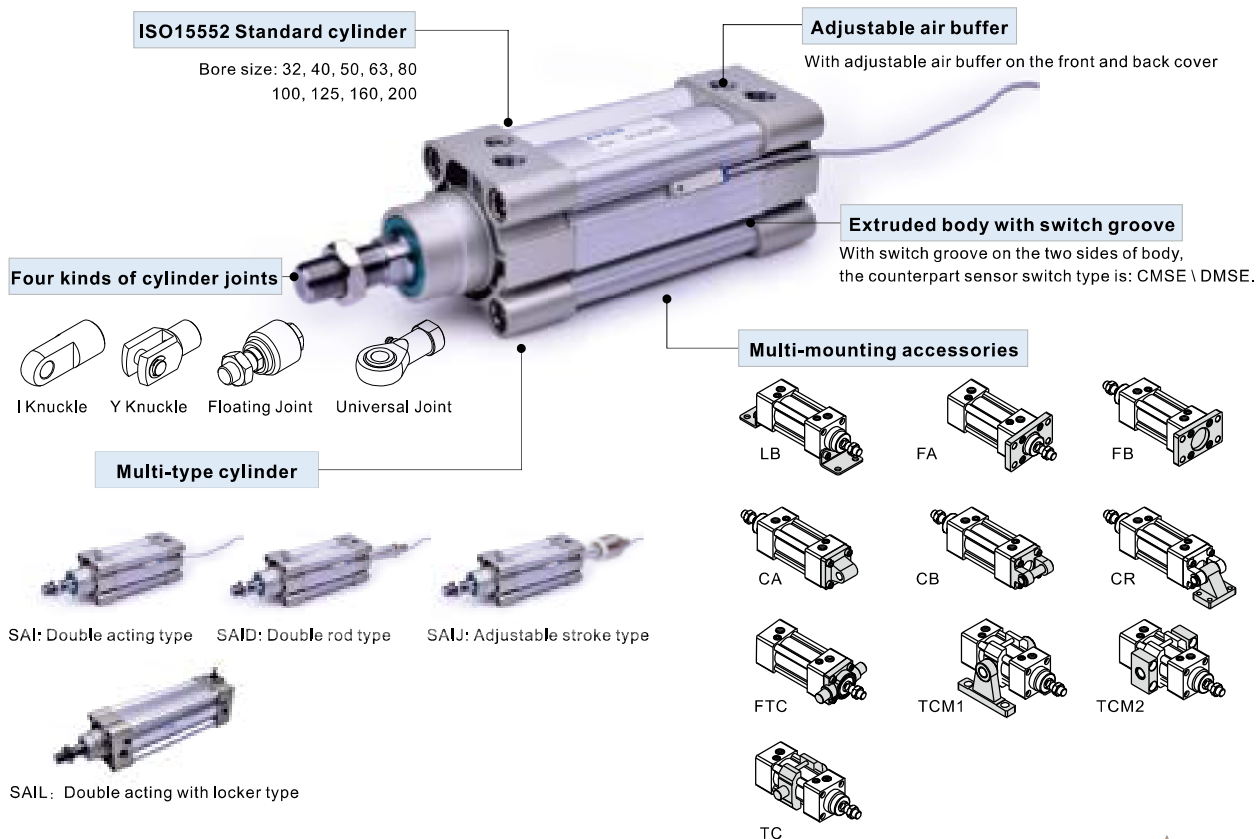

Criteria for selection: Cylinder thrust

Unit: Newton(N)

Bore size	Rod size	Acting type	Pressure area(mm ²)	Operating pressure(MPa)									
				0.1	0.2	0.3	0.4	0.5	0.6	0.7	0.8	0.9	
32	12	Double acting	Push side	804	80.4	160.8	241.2	321.6	402.0	482.4	562.8	643.2	723.6
			Pull side	690	69.0	138.0	207.0	276.0	345.0	414.0	483.0	552.0	621.0
40	16	Double acting	Push side	1256	125.6	251.2	376.8	502.4	628.0	753.6	879.2	1002.4	1130.4
			Pull side	1055	105.5	211.0	316.5	422.0	527.5	633.0	738.5	844.0	949.5
50	20	Double acting	Push side	1963	196.3	392.6	588.9	785.2	981.5	1177.8	1374.1	1570.4	1766.7
			Pull side	1649	164.9	329.8	494.7	659.6	824.5	989.4	1154.3	1399.2	1484.1
63	20	Double acting	Push side	3117	311.7	623.4	935.1	1246.8	1558.5	1870.2	2181.9	2493.6	2805.3
			Pull side	2803	280.3	560.6	840.9	1121.2	1401.5	1681.8	1962.1	2242.4	2522.7
80	25	Double acting	Push side	5026	502.6	1005.2	1507.8	2010.4	2513.0	3015.6	3518.2	4020.8	4523.4
			Pull side	4536	453.6	907.2	1360.8	1814.4	2268.0	2721.6	3175.2	3628.8	4082.4
100	25	Double acting	Push side	7853	785.3	1570.6	2355.9	3141.2	3926.5	4711.8	5497.1	6282.4	7067.7
			Pull side	7362	736.2	1472.4	2208.6	2948.6	3681.0	4417.2	5153.4	5889.6	6625.8
125	32	Double acting	Push side	12272	1227.2	2454.4	3681.6	4908.8	6136.0	7363.2	8590.4	9817.6	11044.8
			Pull side	11468	1146.8	2293.6	3440.4	4587.2	5734.0	6880.8	8027.6	9174.4	10321.2
160	40	Double acting	Push side	20106	2010.6	4021.2	6031.8	8042.4	10053.0	12063.6	14074.2	16084.8	18095.4
			Pull side	18849	1884.9	3769.8	5654.7	7539.6	9424.5	11309.4	13194.3	15079.2	16964.1
200	40	Double acting	Push side	31416	3141.6	6283.2	9424.8	12566.4	15708.0	18849.6	21991.2	25132.8	28274.4
			Pull side	30157	3015.7	6031.4	9047.1	12062.8	15078.5	18094.2	21109.9	24126.6	27141.3

Installation and application



- When load changes in the work, the cylinder with abundant output capacity shall be selected.
- Relative cylinder with high temperature resistance or corrosion resistance shall be chosen under the condition of high temperature or corrosion.
- Necessary protection measure shall be taken in the environment with higher humidity, much dust or water drops, oil dust and welding dregs.
- Dirty substances in the pipe must be eliminated before cylinder is connected with pipeline to prevent the entrance of particles into the cylinder.
- The medium used by cylinder shall be filtered to 40µm or below.
- Anti-freezing measure shall be adopted under low temperature environment to prevent moisture freezing.
- The cylinder shall be carried out test run without load before application. Prior to run, buffer shall be turned to the minimum and gradually released to avoid the damage on cylinder caused by excessive impact.
- The cylinder shall avoid the influence of side load in operation to maintain the normal work of cylinder and extend the service life.
- If the cylinder is dismantled and stored for a long time, please conduct anti-rust treatment to the surface. Anti-dust caps shall be added in air inlet and outlet ports.

ISO15552 Standard cylinder

SAI Series



Specification

Bore size(mm)	32	40	50	63	80	100	125	160	200
Acting type	Double acting								
Fluid	Air(to be filtered by 40µm filter element)								
Mounting type	SAI	Basic FA FB CA CB CR LB TC			FTC TCM1 TCM2				
	SAID、SAIJ	Basic FA LB TC FTC TCM1 TCM2							
Operating pressure	0.15~1.0MPa(22~145psi)(1.5~10.0bar)								
Proof pressure	1.5MPa(215psi)(15bar)								
Temperature °C	-20~70								
Speed range mm/s	30~800			30~500					
Stroke tolerance	0~250 ^{+1.0} ₀		251~1000 ^{+1.5} ₀		1001~1500 ^{+2.0} ₀				
Cushion type	Variable cushion								
Adjustable cushion stroke	27		30		36		40		50
Port size [Note1]	1/8"	1/4"	3/8"		1/2"		3/4"		

[Note1] G thread is available.
Add) Refer to P590 for detail of sensor switch.

Stroke

Bore size (mm)	Standard stroke (mm)	Max.std stroke	Max. stroke
32	25 50 75 80 100 125 150 160 175 200 250 300 350 400 450 500	1000	1800
40	25 50 75 80 100 125 150 160 175 200 250 300 350 400 450 500 600 700 800	1200	1800
50	25 50 75 80 100 125 150 160 175 200 250 300 350 400 450 500 600 700 800 900 1000	1200	1800
63	25 50 75 80 100 125 150 160 175 200 250 300 350 400 450 500 600 700 800 900 1000	1500	1800
80	25 50 75 80 100 125 150 160 175 200 250 300 350 400 450 500 600 700 800 900 1000	1500	1800
100	25 50 75 80 100 125 150 160 175 200 250 300 350 400 450 500 600 700 800 900 1000	1500	1800
125	25 50 75 80 100 125 150 160 175 200 250 300 350 400 450 500 600 700 800 900 1000	1500	1800
160	25 50 75 80 100 125 150 160 175 200 250 300 350 400 450 500 600 700 800 900 1000	1500	2000
200	25 50 75 80 100 125 150 160 175 200 250 300 350 400 450 500 600 700 800 900 1000	1500	2000

[Note] Consult us for non-standard stroke.

Symbol

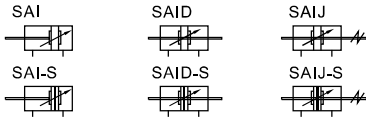

Product feature

- ISO15552 (original ISO6431) standard cylinder;
- The piston seal adopts heterogeneous two way seal structure, with tight dimension and oil reservation function;
- The aluminum profile without tie rod has good corrosion resistance. With sensor switch groove on the two sides of body;
- The buffer adjustment of cylinder is smooth and steady;
- Cylinders and accessories for installation with several specifications are optional;
- The seal material with high temperature resistance is adopted, operating temperature range is 0~150°C.

Ordering code

SAI 160 □ × 50 S □ □ G
 SAID160 □ × 50 S □ □ G
 SAIJ 160 □ × 50-20 S □ □ G

① ② ③ ④ ⑤ ⑥ ⑦ ⑧ ⑨

① Model	② Bore size	③ Rod Material	④ Stroke	⑤ Adjustable stroke	⑥ Magnet	⑦ Mounting type[Note1]	⑧ Seals Material	⑨ Thread type
SAI: Double acting type	32 40 50 63 80 100 125 160 200	Blank: Medium carbon steel A: SUS420J2 B: SUS304	Refer to stroke table for details	No this code	Blank: Without magnet S: With magnet	Blank LB FA FB CA CB CR FTC TC	Blank: TPU H: Viton N: NBR	G: G Thread
SAID: Double rod type						Blank LB FA		
SAIJ: Adjustable stroke type				10 20 30 40 50 75 100		FTC TC		

[Note1] CR is used with CB ; FTC、TC are used with TCM1、TCM2, please refer to page 296~298 for details.



SAI Series

Inner structure and material of major parts

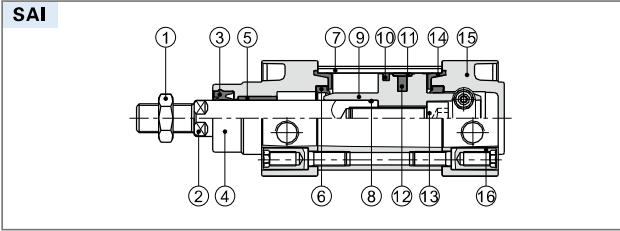

Note: inner structure & material data sheet is based on certain bore size.
Please contact AirTAC if you need inner structure & material data sheet for specific bore size.

NO.	Item	Material
1	Rod nut	Carbon steel/Stainless steel
2	Piston rod	Carbon steel with 20μm chrome plated or Stainless steel
3	Front cover packing	TPU
4	Front cover	Aluminum alloy
5	Bushing	Wear resistant material
6	Cushing O-ring	TPU
7	Barrel	Aluminum alloy
8	O-ring	NBR
9	Piston	Aluminum alloy
10	Piston Seal	NBR
11	Wear ring	Wear resistant material
12	Magnet	Plastic(Φ 100 and below)/Rubber(Others)
13	Bolt	Carbon steel
14	Buffer gasket	TPU
15	Back cover	Aluminum alloy
16	Screw	Carbon steel/Stainless steel

Dimensions

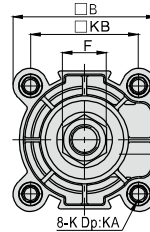
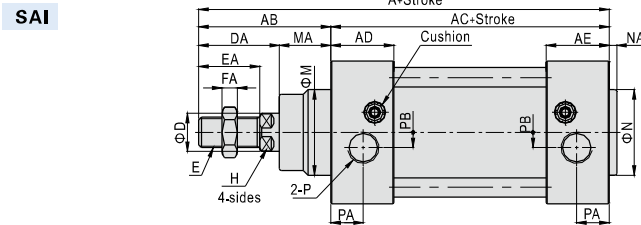

Bore size\Item	A	AB	AC	AD	AE	B	D	DA	E	EA	F	FA	M	MA	H	K	KA	KB	N	NA	P	PA	PB
32	142	48	94	27.5	27.5	47	12	29	M10×1.25	22	17	6	30	19	10	M6	16	32.5	30	3	1/8"	13	5.5
40	159	54	105	32	32	53	16	33	M12×1.25	24	17	7	35	21	13	M6	17	38	35	3.5	1/4"	17	6
50	175	69	106	31	31	65	20	42	M16×1.5	32	23	8	40	27	17	M8	17	46.5	40	3.5	1/4"	15.5	7.5
63	190	69	121	33	33	75	20	42	M16×1.5	32	23	8	45	27	17	M8	17	56.5	45	4	3/8"	16.5	7.5
80	214	86	128	33	33	95	25	53	M20×1.5	40	26	10	45	33	22	M10	19	72	45	4	3/8"	16.5	9
100	229	91	138	37	37	115	25	55	M20×1.5	40	26	10	55	36	22	M10	19	89	55	4	1/2"	18.5	9.5
125	279	119	160	46	46	140	32	74	M27×2.0	54	41	13.5	60	45	27	M12	22	110	60	4	1/2"	23	14
160	332	152	180	50	50	180	40	94	M36×2.0	72	55	18	65	58	36	M16	30	140	65	4	3/4"	25	15
200	347	167	180	50	50	220	40	100	M36×2.0	72	55	18	75	67	36	M16	30	175	75	5	3/4"	25	15

Remark: The dimensions of magnet type cylinder are the same as non-magnet type cylinder.

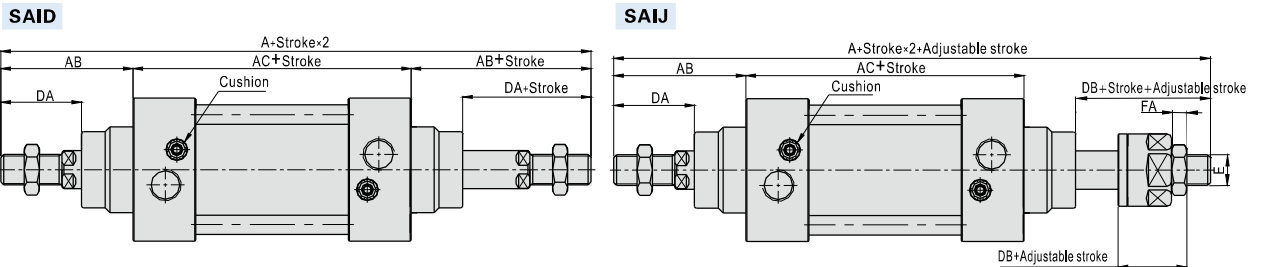

Bore size\Item	A		AB	AC	DA	DB	E	FA
	SAID	SAIJ						
32	190	188	48	94	29	27	M10X1.25	6
40	213	208	54	105	33	28	M12X1.25	7
50	244	231	69	106	42	29	M16X1.5	8
63	259	246	69	121	42	29	M16X1.5	8
80	300	282.5	86	128	53	35.5	M20X1.5	10
100	320	300.5	91	138	55	35.5	M20X1.5	10
125	398	366.5	119	160	74	42.5	M27X2.0	13.5
160	484	458	152	180	94	68	M36X2.0	18
200	514	482	167	180	100	68	M36X2.0	18

Remark:

- The dimensions of magnet type cylinder are the same as non-magnet type cylinder.
- The unmarked dimension is the same as SAI standard type.

ISO15552 Standard cylinder

SAIL Series—With locker type



Specification

Bore size(mm)	40	50	63	80	100	125	160	200			
Acting type	Double acting										
Fluid	Air(to be filtered by 40 μm filter element)										
Mounting type	Basic	FA	FB	CA	CB	CR	LB	TC	FTC	TCM1	TCM2
Operating pressure	0.15~1.0MPa(22~145psi)(1.5~10.0bar)										
Proof pressure	1.5MPa(215psi)(15bar)										
Temperature °C	-20~70										
Speed range mm/s	30~800						30~500				
Stroke tolerance	0~250 ^{+1.0} ₀		251~1000 ^{+1.5} ₀		1001~1500 ^{+2.0} ₀						
Cushion type	Variable cushion										
Adjustable cushion stroke	No locker end	27	30		36		40	50			
	With locker end	20	20	21	22.5	24	24	28			
Port size [Note1]	1/4"		3/8"		1/2"		3/4"				

[Note1] G thread is available.
Add) Refer to P590 for detail of sensor switch.

Stroke

Bore size (mm)	Standard stroke (mm)											Max.std stroke	Max. stroke										
40	25	50	75	80	100	125	150	160	175	200	250	300	350	400	450	500	600	700	800	1200	1800		
50	25	50	75	80	100	125	150	160	175	200	250	300	350	400	450	500	600	700	800	900	1000	1200	1800
63	25	50	75	80	100	125	150	160	175	200	250	300	350	400	450	500	600	700	800	900	1000	1500	1800
80	25	50	75	80	100	125	150	160	175	200	250	300	350	400	450	500	600	700	800	900	1000	1500	1800
100	25	50	75	80	100	125	150	160	175	200	250	300	350	400	450	500	600	700	800	900	1000	1500	1800
125	25	50	75	80	100	125	150	160	175	200	250	300	350	400	450	500	600	700	800	900	1000	1500	1800
160	25	50	75	80	100	125	150	160	175	200	250	300	350	400	450	500	600	700	800	900	1000	1500	2000
200	25	50	75	80	100	125	150	160	175	200	250	300	350	400	450	500	600	700	800	900	1000	1500	2000

[Note] Consult us for non-standard stroke.

Symbol

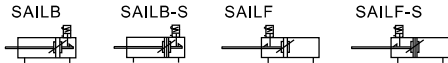

Product feature

1. With lock cylinder: front cover with lock type and rear cover lock type;
2. The way of unlocking: automatic and manual.

Ordering code

SAIL B 160 × 50 S □ G



① Model	② Locker position	③ Bore size	④ Stroke	⑤ Magnet	⑥ Mounting type [Note1]	⑦ Thread type
SAIL: Double acting type (with locker)	B: Back cover with locker F: Front cover with locker	40	Refer to stroke table for details	Blank: Without magnet S: With magnet	Blank	G: G Thread
		50			LB	
		63			FA	
		80			FB	
		100			CA	
		125			CB	
		160			CR	
200	FTC					
					TC	

[Note1] CR is used with CB; FTC, TC are used with TCM1、TCM2, please refer to page 296~298 for details.

Inner structure and material of major parts

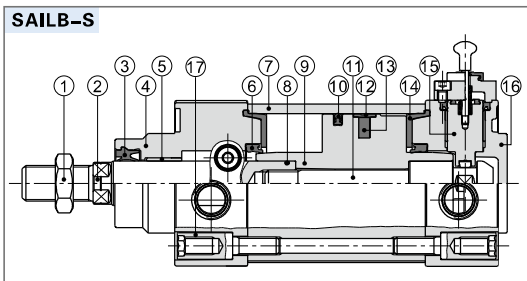

NO.	Item	Material	NO.	Item	Material
1	Rod nut	Carbon steel	9	Piston	Aluminum alloy
2	Piston rod	Carbon steel with 20μm chrome plated	10	Piston Seal	NBR
3	Front cover packing	TPU	11	Pluger	S45C
4	Front cover	Aluminum alloy	12	Wear ring	Wear resistant material
5	Bushing	Wear resistant material	13	Magnet	Plastic(≤100)/Rubber(Others)
6	Cushing O-ring	TPU	14	Buffer gasket	TPU
7	Barrel	Aluminum alloy	15	Locker	
8	O-ring	NBR	16	Back cover	Aluminum alloy
			17	Screw	Carbon steel

Note: inner structure & material data sheet is based on certain bore size. Please contact AirTAC if you need inner structure & material data sheet for specific bore size.

Dimensions

SAILF

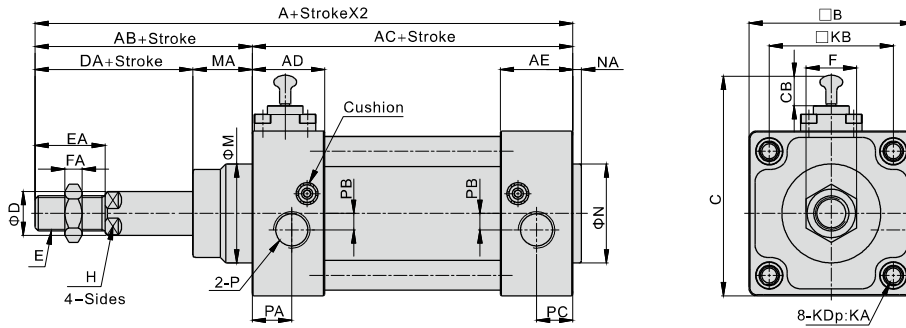

SAILB

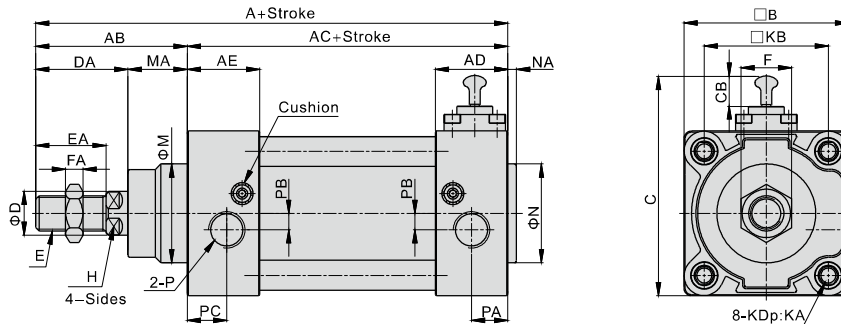

Bore size/Item	A	AB	AC	AD	AE	B	C	CB	D	DA	E	EA	F	FA	H	M	MA	K	KA	KB	N	NA	P	PA	PB	PC
40	159	54	105	32	32	53	78	13.5	16	32	M12×1.25	24	17	7	13	35	22	M6	17	38	35	3.5	1/4"	17	6	17
50	175	69	106	31	31	65	90	13.5	20	42	M16×1.5	32	23	8	17	40	27	M8	17	46.5	40	3.5	1/4"	19.5	7.5	15.5
63	190	69	121	33	33	75	100.5	14	20	40	M16×1.5	32	23	8	17	45	29	M8	17	56.5	45	4	3/8"	18	7.5	16.5
80	220	86	134	39	33	95	123	14.5	25	53	M20×1.5	40	26	10	22	45	33	M10	19	72	45	4	3/8"	22.5	9	16.5
100	231	91	140	39	37	115	142	13.5	25	55	M20×1.5	40	26	10	22	55	36	M10	19	89	55	4	1/2"	20.5	13.5	18.5
125	279	119	160	46	46	140	170.5	14.5	32	74	M27×2.0	54	41	13.5	27	60	45	M12	20	110	60	4	1/2"	23	14	23
160	332	152	180	50	50	180	210.5	14.5	40	94	M36×2.0	72	55	18	36	65	58	M16	30	140	65	4	3/4"	25	15	25
200	347	167	180	50	50	220	250.5	14.5	40	100	M36×2.0	72	55	18	36	75	67	M16	30	175	75	5	3/4"	25	15	25

Remark: The dimensions of magnet type cylinder are the same as non-magnet type cylinder.

Use and maintenance

- Under the condition of locking, there is a great danger to the gas port A when there is no pressure on both sides of the air port. There is a great danger similar to the release of locking, or the sudden release of lock and the piston rod flying. When the locking mechanism is lifted, it is necessary to supply the pressure of the air inlet B and remove the lock mechanism without load.
- If the fast exhaust valve is used to speed down the drop speed, the cylinder phenomenon is sometimes started than the lock pin first and can not be removed normally. Therefore, please do not use the fast exhaust valve with the lock cylinder.
- Please do not use three solenoid valves: please do not combine with three (especially the seal type metal seal) solenoid valve. If pressure is sealed in the air inlet with the locking mechanism side, the lock will not work. In addition, even if it is temporarily locked, the air leaked from the solenoid valve will enter the cylinder, and the lock will be lifted after a period of time.
- If the locking mechanism side bears the back pressure, sometimes the lock will be lifted, so please use a single or integrated individual exhaust type solenoid valve.
- If the cylinder with adjustable cushioning is excessive, if the air cushion valve needle on the locking mechanism side is screwed too much, the piston will sometimes cause restraint at the stroke terminal, causing the damage of the locking mechanism. Therefore, the needle valve should be adjusted to make the piston not be restrained.
- When the manual operation of the locking mechanism is completed, it is necessary to reset the manual device to the in situ. In addition, please do not do manual operation outside the adjustment, otherwise it will be more dangerous.
- When the cylinder is installed and adjusted, please dissolve the lock: in the lock state of the installation and other operations, sometimes it causes the lock-in parts to be damaged.
- Please do not use multiple cylinders at the same time: please do not use more than 2 locking cylinders at the same time to drive a workpiece. Sometimes one of the cylinders will not be locked out.
- Please use the speed control valve in the exhaust throttle control state: in the intake throttling control, it is sometimes impossible to release the lock.
- In the lock side, please be sure to use the terminal of the cylinder stroke: if the piston of the cylinder does not reach the terminal, locking will fail or lock.
- Manual operation is a non locking way to release: pull the lever into the anti falling piston, and pull the bolt out of the 4mm with the force of more than 20N. After the piston is moved away, it can release the lock. (no load level installation or opposite side port pressurization), or after loosened, the anti falling piston returns to the original position through the action of the stop spring and enters the piston rod groove, and the piston becomes locked.

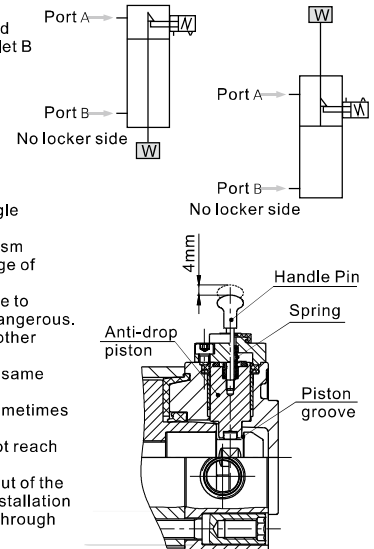



Enclasp cylinder—BSAI Series

In accordance with ISO15552 standard

Compendium of BSAI Series

Spring and gripper patch enclasp equipment

Simplicity structure
Celerity and availability locked or unlocked
State switch steadily

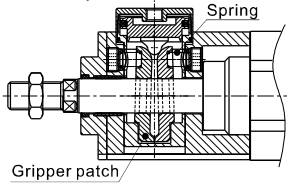

Multi-kinds unlocked mode

Air pressure unlocked mode and manual unlocked mode are available

Air pressure unlocked mode

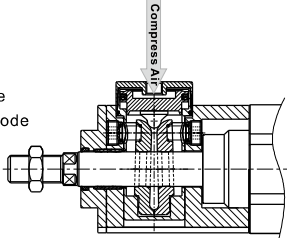

Manual unlocked screw

Manual unlocked mode

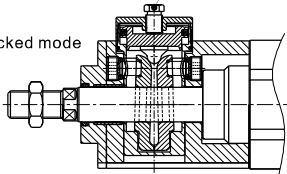

Multi-type cylinder and bore size

BSAI, BSAID type available
Bore size: 32, 40, 50, 63, 80, 100, 125

Bidirectional lock

Can be locked no matter piston shoot out or draw back

Compact enclasp equipment

Compact enclasp equipment to save space

The body is the same as SAI series

The body is SAI series standard cylinder's body for mounting expediently.
The mounting accessories (Besides FTC) and the sensor switch are the same as SAI series cylinder.



How to mount and use

1. The locker equipment only be locked after cylinder stopped, can't brake the piston rod while it is moving. If the lock cylinder be used for control system with safety demand, other safety measure is required.
2. The locker equipment only be unlocked when the air pressure on both sides of piston rod are equation or the cylinder stopped, otherwise piston rod moves abruptly might produce accident.
3. Typical applications

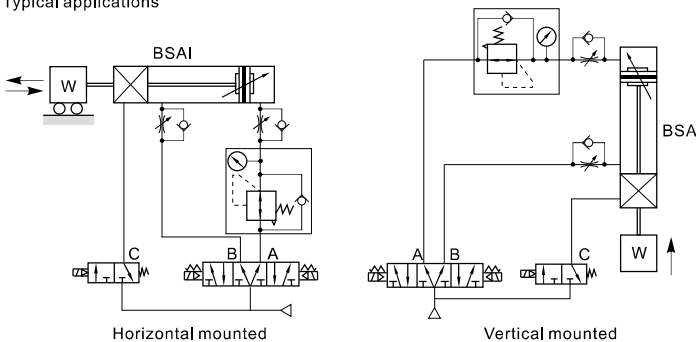

Acting type

Air inlet			State of acting	
A Port	B Port	C Port		
Yes	No	Yes	Advance	
Yes	Yes	No	Locked	Over 0.5S
Yes	Yes	Yes	unlocked	0~0.5S
Yes	No	Yes	Advance to rod protruded completely	
No	Yes	Yes	Back	
Yes	Yes	No	Locked	Over 0.5S
Yes	Yes	Yes	unlocked	0~0.5S
No	Yes	Yes	back to rod retracted completely	

Circle

ISO15552 Standard cylinder

BSAI Series—Enclasp type



Specification

Bore size(mm)	32	40	50	63	80	100	125
Acting type	Double acting						
Fluid	Air(to be filtered by 40μm filter element)						
Mounting type	BSAI	Basic FA FB CA CB CR LB TC TCM1 TCM2					
	BSAID	Basic FA LB TC TCM1 TCM2					
Operating pressure	0.15~0.7MPa(22~100psi)(1.5~7.0bar)						
Proof pressure	1.5MPa(215psi)(15bar)						
Temperature °C	-20~70						
Speed range mm/s	30~800						30~500
Stroke tolerance	0~250		0 ^{+1.0} ₀ 251~1000 ^{+1.5} ₀		1001~1500 ^{+2.0} ₀		
Cushion type	Variable cushion						
Adjustable cushion stroke	27		30		36		40
Port size	Cylinder	1/8"	1/4"	3/8"		1/2"	
[Note1] Enclasp equipment	G1/8						
Unlocked Pressure	0.15~0.7MPa(22~100psi)(1.5~7bar)						
Static holding force (N)	600	900	1400	2200	3600	5500	8600

[Note1] G thread is available.
Add) Refer to P590 for detail of sensor switch.

Symbol

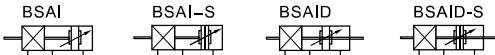

Product feature

1. Belong to SAI series standard cylinder add lock structure.
2. Can be locked at random positions in stroke scope.
3. Reasonable lock structure, the lock state no relation with the direction of piston moving.

Stroke

Bore size (mm)	Standard stroke (mm)	Max.std stroke
32	25 50 75 80 100 125 150 160 175 200 250 300 350 400 450 500	700
40	25 50 75 80 100 125 150 160 175 200 250 300 350 400 450 500 600 700 800	800
50	25 50 75 80 100 125 150 160 175 200 250 300 350 400 450 500 600 700 800 900 1000	1000
63	25 50 75 80 100 125 150 160 175 200 250 300 350 400 450 500 600 700 800 900 1000	1000
80	25 50 75 80 100 125 150 160 175 200 250 300 350 400 450 500 600 700 800 900 1000	1000
100	25 50 75 80 100 125 150 160 175 200 250 300 350 400 450 500 600 700 800 900 1000	1000
125	25 50 75 80 100 125 150 160 175 200 250 300 350 400 450 500 600 700 800 900 1000	1000

[Note] Consult us for non-standard stroke.

Ordering code

B SAI 80X50 S □ G
B SAID 80X50 S □ G

① ② ③ ④ ⑤ ⑥ ⑦

① Type	B: Enclasp cylinder			
② Model	SAI: Double acting type		SAID: Double rod type	
③ Bore size	32 40 50 63 80 100 125			
④ Stroke	Refer to stroke table for details			
⑤ Magnet	Blank: Without magnet		S: With magnet	
⑥ Mounting type [Note1]	Blank	LB	Blank	LB
	FA	FB	FA	TC
	CA	CB		
	CR	TC		
⑦ Thread type	G: G Thread			

[Note1] CR is used with CB; TC are used with TCM1、TCM2, please refer to page 296~298 for details.

ISO15552 Standard cylinder

BSAI Series—Enclasp type

Inner structure and material of major parts

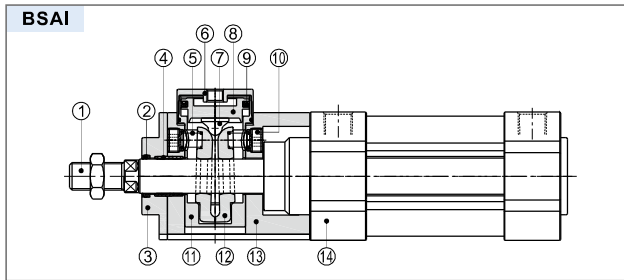

NO.	Item	Material
1	Piston rod	Carbon steel with 20 μm chrome plated
2	Packing	Plastic
3	Packing holder	Aluminum alloy
4	Bearing	Carbon steel+Bronze sinter
5	Spring	Spring steel
6	Cover	Aluminum alloy
7	Unlocked header	Wear resistant material
8	Unlocked piston	Aluminum alloy
9	Piston O-ring	NBR
10	Screw	Carbon steel
11	Sleeve	Aluminum alloy
12	Clamp head	Aluminium bronze
13	Fixed holder	Aluminum alloy
14	SAI series cylinder	-

Note: inner structure & material data sheet is based on certain bore size.
Please contact AirTAC if you need inner structure & material data sheet for specific bore size.

Dimensions

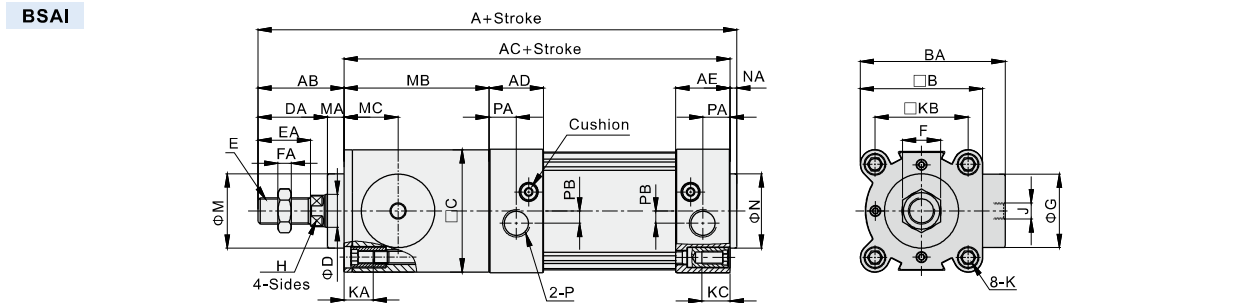

Bore size\Item	A	AB	AC	AD	AE	B	BA	C	D	DA	E	EA	F	FA	G	H	J	K	KA	KB	KC	M	MA	MB	MC	P	PA	PB	N	NA
32	201	39	159	27.5	27.5	47	65	46.5	12	29	M10×1.25	22	17	6	30	10	G1/8	M6X1.0	14.5	32.5	16	20	10	65	25	1/8"	13.5	6	30	3
40	222.5	43	176	32	32	53	73	52.5	16	33	M12×1.25	24	17	7	36.5	13	G1/8	M6X1.0	14.5	38	17	35	10	71	27.5	1/4"	17.5	6	35	3.5
50	249.5	52	194	31	31	65	83	64	20	42	M16×1.5	32	23	8	44.5	17	G1/8	M8X1.25	17.5	46.5	17	40	10	88	33	1/4"	14	8	40	3.5
63	265	52	209	33	33	75	88	74	20	42	M16×1.5	32	23	8	44.5	17	G1/8	M8X1.25	17.5	56.5	17	45	10	88	33	3/8"	17	8	45	4
80	321	68	249	33	33	95	107.5	94	25	53	M20×1.5	40	26	10	55.5	22	G1/8	M10X1.5	17	72	19	45	15	121	47	3/8"	16.5	8	45	4
100	336	70	262	37	37	115	117.5	113.5	25	55	M20×1.5	40	26	10	55.5	22	G1/8	M10X1.5	17	89	19	55	15	124	47	1/2"	19.5	10	55	4
125	401	92	305	46	46	140	152	138	32	74	M27×2	54	41	13.5	70	27	G1/8	M12X1.75	21.5	110	22	60	18	145	63	1/2"	23	11	60	4

Remark: The dimensions of magnet type cylinder are the same as non-magnet type cylinder.

BSAID

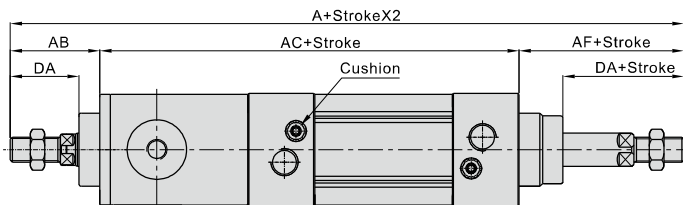

Bore size\Item	A	AB	AC	AF	DA	E	FA
32	246	39	159	48	29	M10×1.25	6
40	273	43	176	54	33	M12×1.25	7
50	315	52	194	69	42	M16×1.5	8
63	330	52	209	69	42	M16×1.5	8
80	408	68	249	86	53	M20×1.5	10
100	448	70	262	95	55	M20×1.5	10
125	516	92	305	119	74	M27×2	13.5

Note: inner structure & material data sheet is based on certain bore size.
Please contact AirTAC if you need inner structure & material data sheet for specific bore size.

Remark:
1. The dimensions of magnet type cylinder are the same as non-magnet type cylinder.
2. The unmarked dimension is the same as BSAI standard type.

SAI Series—Accessories

List for ordering code of accessories

Accessories Bore size	Mounting accessories								
	LB	FA/FB	CA	CB	CR	TC	FTC	TCM1	TCM2
32	F-SI32LB	F-SI32FA	F-SE32CA	F-SE32CB	F-SI32CR	F-SAI32TC	F-SI32FTC	F-SI32TCM1	F-SI32TCM2
40	F-SI40LB	F-SI40FA	F-SE40CA	F-SE40CB	F-SI40CR	F-SAI40TC	F-SI40FTC	F-SI40TCM1	F-SI40TCM2
50	F-SI50LB	F-SI50FA	F-SE50CA	F-SE50CB	F-SI50CR	F-SAI50TC	F-SI50FTC	F-SI40TCM1	F-SI40TCM2
63	F-SI63LB	F-SI63FA	F-SE63CA	F-SE63CB	F-SI63CR	F-SAI63TC	F-SI63FTC	F-SI63TCM1	F-SI63TCM2
80	F-SI80LB	F-SI80FA	F-SE80CA	F-SE80CB	F-SI80CR	F-SAI80TC	F-SI80FTC	F-SI63TCM1	F-SI63TCM2
100	F-SI100LB	F-SI100FA	F-SE100CA	F-SE100CB	F-SI100CR	F-SAI100TC	F-SI100FTC	F-SI125TCM1	F-SI125TCM2
125	F-SI125LB	F-SI125FA	F-SE125CA	F-SE125CB	F-SI125CR	F-SAI125TC	F-SI125FTC	F-SI125TCM1	F-SI125TCM2
160	F-SI160LB	F-SI160FA	F-SI160CA	F-SI160CB	F-SI160CR	F-SI160TC	F-SI160FTC	F-SI160TCM1	F-SI160TCM2
200	F-SI200LB	F-SI200FA	F-SI200CA	F-SI200CB	F-SI200CR	F-SI200TC	F-SI200FTC	F-SI200TCM1	F-SI160TCM2

Accessories Bore size	Knuckle				Sensor switch	
	I	Y	F	U	CMSE	DMSE
32	F-M10X125I	F-M10X125Y	F-M10X125F	F-M10X125U	CMSE	DMSE
40	F-M12X125I	F-M12X125Y	F-M12X125F	F-M12X125U		
50	F-M16X150I	F-M16X150Y	F-M16X150F	F-M16X150U		
63	F-M16X150I	F-M16X150Y	F-M16X150F	F-M16X150U		
80	F-M20X150I	F-M20X150Y	F-M20X150F	F-M20X150U		
100	F-M20X150I	F-M20X150Y	F-M20X150F	F-M20X150U		
125	F-M27X200I	F-M27X200Y	F-M27X200F	F-M27X200U		
160	F-M36X200I	F-M36X200Y	F-M36X200F	F-M36X200U		
200	F-M36X200I	F-M36X200Y	F-M36X200F	F-M36X200U		

Accessory selection

Accessories Cylinder model	Mounting accessories										Knuckle [Note1]				Sensor switch	
	LB	FA	FB	CA	CB	CR	TC	FTC	TCM1	TCM2	I	Y	U	F	CMSE	DMSE
SAI	Standard	●	●	●	●	●	●	●	●	●	●	●	●	●	●	●
	With magnet	●	●	●	●	●	●	●	●	●	●	●	●	●	●	●
SAIL	Standard	●	●	●	●	●	●	●	●	●	●	●	●	●	●	●
	With magnet	●	●	●	●	●	●	●	●	●	●	●	●	●	●	●
BSAI	Standard	●	●	●	●	●	●	●	●	●	●	●	●	●	●	●
	With magnet	●	●	●	●	●	●	●	●	●	●	●	●	●	●	●
SAID	Standard	●	●	×	×	×	×	●	●	●	●	●	●	●	●	●
	With magnet	●	●	×	×	×	×	●	●	●	●	●	●	●	●	●
BSAID	Standard	●	●	×	×	×	×	●	●	●	●	●	●	●	●	●
	With magnet	●	●	×	×	×	×	●	●	●	●	●	●	●	●	●
SAIJ	Standard	●	●	×	×	×	×	●	●	●	●	●	●	●	●	●
	With magnet	●	●	×	×	×	×	●	●	●	●	●	●	●	●	●

[Note1] Please refer to P586-589 for knuckle detail.

Material of accessories

Accessories Bore size	Mounting accessories										Knuckle			
	LB	FA	FB	CA	CB	CR	TC	FTC	TCM1	TCM2	I	Y	F	U
32~100	○	●	●	◇	◇	◇	◇	◇	◇	●	□	□	□	□
125~200	◇	◇	◇	◇	◇	◇	◇	◇	◇	●	◇	◇	□	□

●—Aluminum alloy, ○—SPCC, ◇—Nodular cast iron, □—Carbon steel.

Installation of TC bracket

Follow below steps to install TC brackets:

- Assemble TC bracket onto barrel and move it to the desired position.
- Slightly tighten screws and make sure the surface of groove of bracket is closely attached to protruded parts on the barrel.
- Bore 32~40: Tightening up 8 black stop screws (Light torque - Middle torque - Fastened). See below table for recommended tightening torque.
Bore 50~125: Tightening up 8 black stop screws first (Light torque - Middle torque - Fastened), then the 8 white stop screws. See below table for recommended tightening torque.

Bore size	32	40	50	63	80	100	125
Max locking moment M(N.m)	2~3	4~6	4~6	4~6	8~10	8~10	10~12
Static holding force F(N)	800	1200	2000	3000	5000	8000	12000

Note: If customer needs holding force larger than the figures stated in above table, please contact us for customization of fixed TC design (Non-movable TC bracket).



ISO15552 Standard cylinder

SAI Series—Accessories

Dimensions

LB

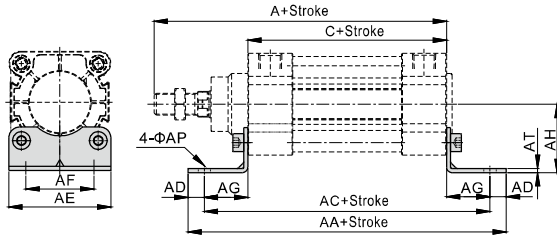

Bore size/Item	A	C	AA	AC	AD	AE	AF	AG	AH	AP	AT
32	142	94	158	142	8	47	32	24	32	7	3
40	159	105	179	161	9	53	36	28	36	9	3
50	175	106	190	170	10	65	45	32	45	9	3
63	190	121	209	185	12	75	50	32	50	9	3
80	214	128	248	210	19	95	63	41	63	12.5	4
100	229	138	266	220	23	115	75	41	71	14.5	4
125	279	160	290	250	20	140	90	45	90	16.5	8
160	332	180	340	300	20	180	115	60	115	18.5	10.5
200	347	180	380	320	30	220	135	70	135	24	9

CA

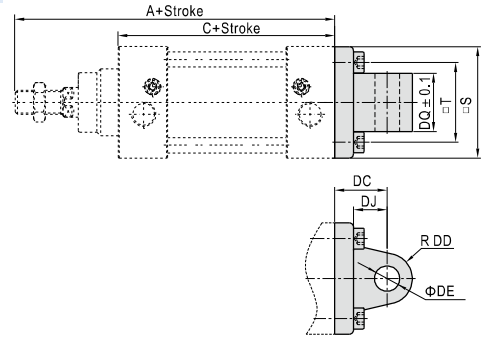

Bore size/Item	A	C	S	T	DC	DD	DE	DJ	DQ
32	142	94	46.5	32.5	22	10.5	10	13	25.8
40	159	105	54	38	25	12	12	16	27.8
50	175	106	64	46.5	27	12	12	17	31.7
63	190	121	75	56.5	32	15	16	22	39.7
80	214	128	93	72	36	15.5	16	22	49.7
100	229	138	110	89	41	20	20	27	59.7
125	279	160	134	110	50	24	25	33	69.7
160	332	180	180	140	55	30	30	35.5	89.7
200	347	180	220	175	60	30	30	37	89.7

FA/FB

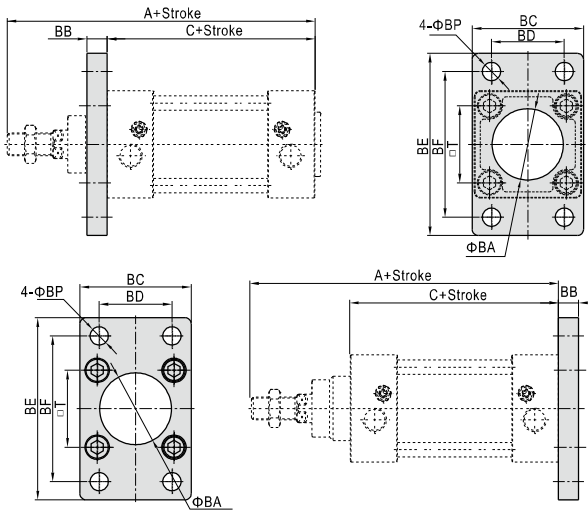

Bore size/Item	A	C	BA	BB	BC	BD	BE	BF	BP	T
32	142	94	30.5	10	47	32	80	64	7	32.5
40	159	105	35.5	10	53	36	90	72	9	38
50	175	106	40.5	12	65	45	108	90	9	46.5
63	190	121	45.5	12	75	50	118	100	9	56.5
80	214	128	45.5	16	95	63	150	126	12.5	72
100	229	138	55.5	16	115	75	176	150	14.5	89
125	279	160	60.5	20	139	90	218	180	16.5	110
160	332	180	65.5	20	180	115	280	230	18.5	140
200	347	180	75.5	25	220	135	320	270	24	175

CB

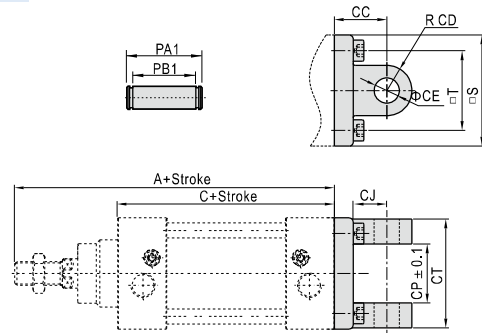

Bore size/Item	A	C	CC	CD	CE	CJ	CP	CT	PA1	PB1	S	T
32	142	94	22	10.5	10	13	26	45	51	45.5	46.5	32.5
40	159	105	25	12	12	16	28	52	59	52.5	54	38
50	175	106	27	12	12	17	32	60	67	60.5	64	46.5
63	190	121	32	15	16	22	40	70	77	70.5	75	56.5
80	214	128	36	15	16	22	50	90	97	90.5	93	72
100	229	138	41	20	20	27	60	110	119	110.5	110	89
125	279	160	50	24	25	33	70	130	139	130.5	134	110
160	332	180	55	30	30	35.5	90	170	181	170.5	180	140
200	347	180	60	30	30	36	90	170	181	170.5	220	175

ISO15552 Standard cylinder

SAI Series—Accessories

TC

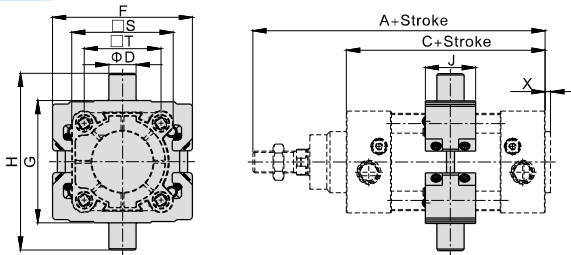

Bore size/Item	A	C	D	F	G	H	J	S	X	T
32	142	94	12	68.5	52	76	31	47	3	32.5
40	159	105	16	75	63	95	31	53	3.5	38
50	175	106	16	91	75	107	35	65	3.5	46.5
63	190	121	20	103	90	130	35	75	4	56.5
80	214	128	20	126	110	150	45	95	4	72
100	229	138	25	145	132	182	45	115	4	89
125	279	160	25	175	160	210	51	140	4	110
160	332	180	32	210	200	264	50	180	4	140
200	347	180	32	255	250	314	50	220	5	175

[Note] 160 and 200 TC accessory has been installed on the barrel of cylinder before it worked off, and the position of the accessories can not be adjusted arbitrarily. If consumer orders the TC solely, he will not install it on the barrel of standard cylinder directly.

FTC

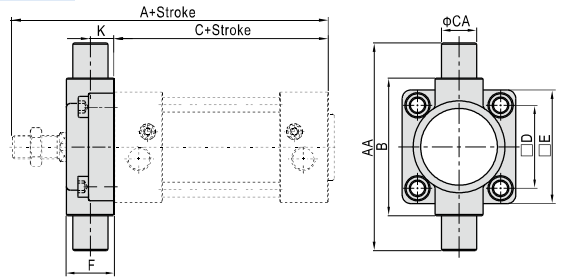

Bore size/Item	A	C	AA	B	CA	D	E	F	K
32	142	94	74	50	12	32.5	46	19	10
40	159	105	95	63	16	38	52	21	10
50	175	106	107	75	16	46.5	64	26	12
63	190	121	130	90	20	56.5	74	28	12
80	214	128	150	110	20	72	94	31	16
100	229	138	182	132	25	89	114	35	16
125	279	160	210	160	25	110	139	43	20
160	332	180	264	200	32	140	179	56	20
200	347	180	314	250	32	175	218	64	20

TCM1

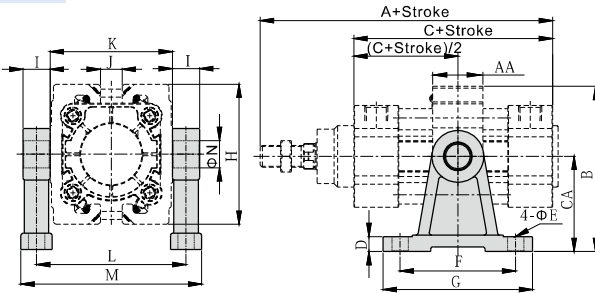

Bore size/Item	A	C	AA	B	CA	D	E	F	G	H	I	J	K	L	M	N
32	142	94	31	72.5	40	11	9	60	80	65	12	5	52	64	79	12
40	159	105	31	91.5	54	11	12	75	100	75	16	8	63	79	98	16
50	175	106	35	99.5	54	11	12	75	100	91	16	10	75	91	110	16
63	190	121	35	121.5	70	11	12	85	110	103	20	16	90	110	133	20
80	214	128	45	133	70	11	12	85	110	126	20	20	110	130	153	20
100	229	138	45	162.5	90	19	18	115	155	145	25	28	132	157	185	25
125	279	160	51	177.5	90	19	18	115	155	175	25	40	160	185	213	25
160	332	180	50	215	110	24	22	140	190	210	32	100	200	232	267	32
200	347	180	50	262.5	135	27	22	150	200	255	32	125	250	282	317	32

[Note] 160/200 installation position of the accessories can not be adjusted arbitrarily.

TCM2

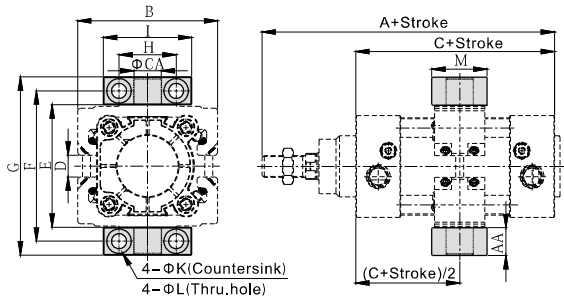

Bore size/Item	A	AA	B	C	CA	D	E	F	G	H	I	K	L	M
32	142	14	65	94	12	5	52	68	82	32	46	11	7	30
40	159	17	75	105	16	8	63	82	99	36	55	15	9	36
50	175	17	91	106	16	10	75	94	111	36	55	15	9	36
63	190	20.5	103	121	20	16	90	113.5	134	42	65	18	11	40
80	214	20.5	126	128	20	20	110	133.5	154	42	65	18	11	40
100	229	24.5	145	138	25	28	132	159.5	184	50	75	20	14	50
125	279	24.5	175	160	25	40	160	187.5	212	50	75	20	14	50
160	332	30	210	180	32	100	200	234	264	60	92	26	18	60
200	347	30	255	180	32	125	250	284	314	60	92	26	18	60

[Note] 160/200 installation position of the accessories can not be adjusted arbitrarily.

CR

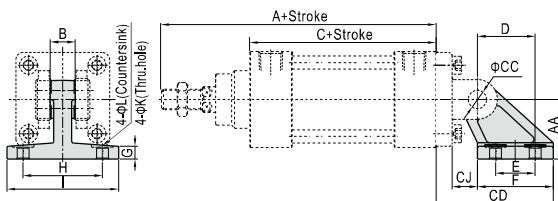

Bore size/Item	A	AA	B	C	CC	CD	CJ	D	E	F	G	H	I	K	L
32	142	32	26	94	10	49	10	21	18	30	8	38	50	6.5	10.5
40	159	36	28	105	12	55	12	24	22	34	10	41	53	6.5	10.5
50	175	45	32	106	12	67	13	33	30	44	12	50	64	9	14
63	190	50	40	121	16	76	17	37	35	49	12	52	66	9	14
80	214	63	50	128	16	92.5	19.5	47	40	59	14	66	85	11	17
100	229	71	60	138	20	105.5	22.5	55	50	69	15	76	95	11	17
125	279	90	70	160	25	134	29	70	60	88	20	94	122	13.5	20
160	332	115	90	180	30	171	25.5	97	88	126	25	118	156	13.5	20
200	347	135	90	180	30	185	31	105	90	130	30	122	162	18	26

[Note] CR can't be used alone, it must be used with CB.